

1

2

3

PART NO	REV
FS-CI0209-AA	AA

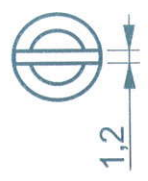

PLAN

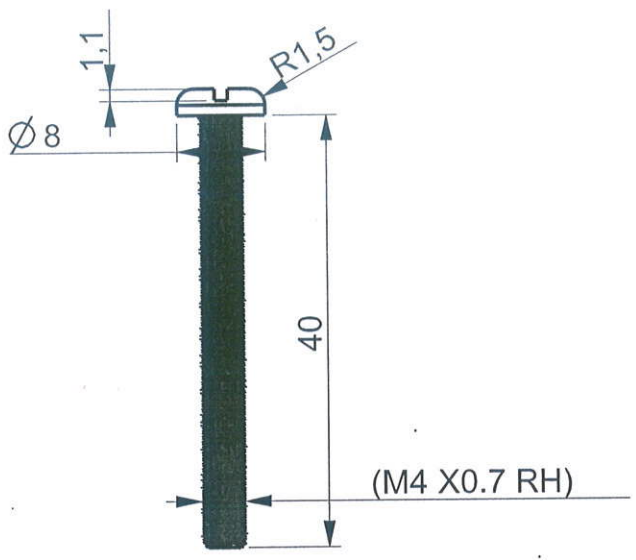

ELEVATION

MATING PARTS

- NOTES
- 1.ALL DIMENSIONS ARE IN MM.
 - 2.PART SHOULD BE FREE FROM BURRS & SHARP EDGES.
 - 3.DO NOT MEASURE FROM THE DRAWING.

AA	DRAWING RELEASE	-	KRS	--	
REV	DESCRIPTION OF CHANGE	LOC	BY	E.N.	DATE

ALL DIMENSIONS ARE IN MM	GENERAL TOLERANCES					ALL RIGHTS RESERVED MAYA APPLIANCES (P) LTD, CHENNAI-97, INDIA.			
DIMENSIONS	$\frac{0.5}{6}$	$\frac{6}{30}$	$\frac{30}{120}$	$\frac{120}{400}$	$\frac{400}{1000}$	MATERIAL	SS	GRADE	304

TOLERANCES ±	0.1	0.2	0.3	0.4	0.8	COLOUR	NATURAL	FINISH	POLISHED
ANGULAR TOLERANCE- ±1/2°	CONCENTRICITY- Ø0.1					COLOUR	NATURAL	FINISH	POLISHED

REFERENCE	--	* CRITICAL DIMENSIONS.	PART NO : FS-CI0209-AA			REV	AA
-----------	----	------------------------	------------------------	--	--	-----	----

ASSEMBLY	COMMON	DENSITY (g/mm ³)	--	DRAWN BY		DATE	6-9-23
----------	--------	------------------------------	----	----------	--	------	--------

MODEL	--	MASS (kg)	--	CHECKED BY	<i>7-5-23</i>	DATE	<i>28-11-23</i>
-------	----	-----------	----	------------	---------------	------	-----------------

DO NOT MEASURE FROM DRAWING		THIRD ANGLE PROJECTION		APPD BY	<i>Sachin</i>	DATE	<i>18/1/24</i>
-----------------------------	--	------------------------	--	---------	---------------	------	----------------

SCALE	4.000	TITLE	SCREW SS M4 X 40 MM(PAN WITH MINUS HEAD)	SHEET SIZE	A4	SHEET OF	1 OF 1
-------	-------	-------	---	------------	----	----------	--------

1

2

3