

1

2

3

PART NO	REV
FS-CI0193-AA	A

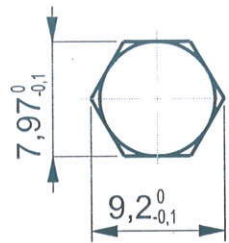

TOP VIEW

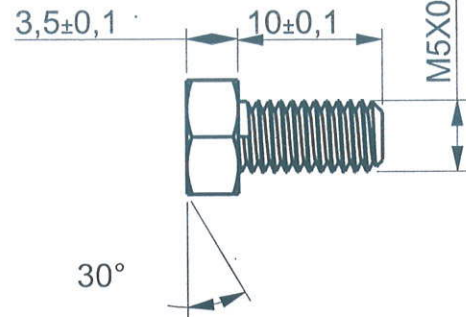

SIDE VIEW

MATING PARTS
TOP CASING
BOTTOM CASING
M5 NUT
M5 WASHER
RUBBER LEG

NOTES
 1.ALL DIMENSIONS ARE IN MM.
 2.PART SHOULD BE FREE FROM BURRS & SHARP EDGES.
 3.DO NOT MEASURE FROM THE DRAWING.

AA	DRAWING RELEASE	--	ANAND	--	6-9-23
REV	DESCRIPTION OF CHANGE	LOC	BY	E.N.	DATE

ALL DIMENSIONS ARE IN MM	GENERAL TOLERANCES					ALL RIGHTS RESERVED MAYA APPLIANCES (P) LTD, CHENNAI-97, INDIA.			
DIMENSIONS	0.5/6	6/30	30/120	120/400	400/1000	MATERIAL	MS	GRADE	--
TOLERANCES ±	0.1	0.2	0.3	0.4	0.8	COLOUR	YELLOW	FINISH	NICKEL PLATED
ANGULAR TOLERANCE- ±1/2°	CONCENTRICITY- Ø0.1								

REFERENCE	--	* CRITICAL DIMENSIONS.		PART NO : FS-CI0193-AA		REV	A	
ASSEMBLY	COMMON	DENSITY (g/mm ³)	--	DRAWN BY	ANAND	DATE	6-9-23	
MODEL	--	MASS (kg)	--	CHECKED BY	<i>J. S. Arj</i>	DATE	28-12-23	
DO NOT MEASURE FROM DRAWING		THIRD ANGLE PROJECTION		APPD BY	<i>Sudhakar</i>	DATE	18/1/24	
SCALE	2.000	TITLE	BOLT MS M5X10			SHEET SIZE	A4	SHEET OF 1 OF 1

1

2

3