

1

2

3

PART NO	REV
FS-CI0192-AA	AA

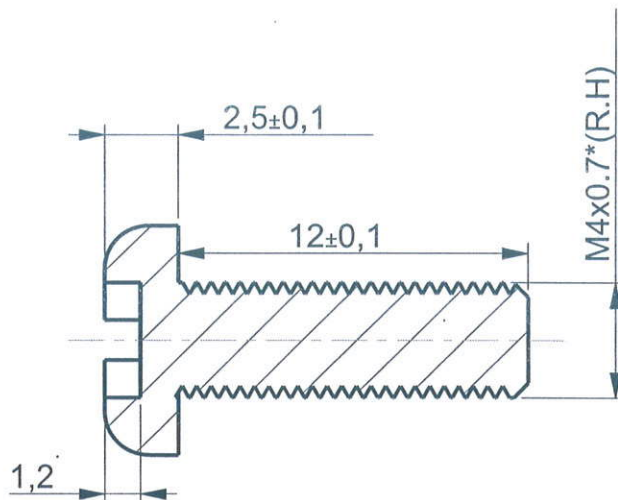
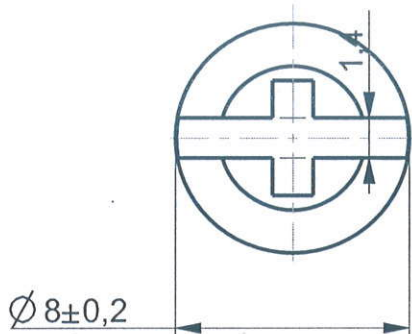

MATING PARTS

NOTES

1. ALL DIMENSIONS ARE IN MM.
2. PART SHOULD BE FREE FROM BURRS & SHARP EDGES.
3. DO NOT MEASURE FROM THE DRAWING.

AA	DRAWING RELEASE	-	KRS	--	
REV	DESCRIPTION OF CHANGE	LOC	BY	E.N.	DATE

ALL DIMENSIONS ARE IN MM

GENERAL TOLERANCES

ALL RIGHTS RESERVED

MAYA APPLIANCES (P) LTD,
CHENNAI-97,
INDIA.

DIMENSIONS	$\frac{0.5}{6}$	$\frac{6}{30}$	$\frac{30}{120}$	$\frac{120}{400}$	$\frac{400}{1000}$
------------	-----------------	----------------	------------------	-------------------	--------------------

TOLERANCES \pm	0.1	0.2	0.3	0.4	0.8
------------------	-----	-----	-----	-----	-----

MATERIAL	SS	GRADE	304
----------	----	-------	-----

ANGULAR TOLERANCE- $\pm 1/2^\circ$	CONCENTRICITY- $\varnothing 0.1$	COLOUR	NATURAL	FINISH	POLISHED
------------------------------------	----------------------------------	--------	---------	--------	----------

REFERENCE	--	* CRITICAL DIMENSIONS.	PART NO : FS-CI0192-AA	REV AA
-----------	----	------------------------	------------------------	--------

ASSEMBLY	COMMON	DENSITY (g/mm ³)	--	DRAWN BY		DATE	11-7-16
----------	--------	------------------------------	----	----------	--	------	---------

MODEL	--	MASS (kg)	--	CHECKED BY	<i>A.S.P.</i>	DATE	28-12-23
-------	----	-----------	----	------------	---------------	------	----------

DO NOT MEASURE FROM DRAWING	THIRD ANGLE PROJECTION		APPD BY	<i>Sudhakar</i>	DATE	18/1/24
-----------------------------	------------------------	--	---------	-----------------	------	---------

SCALE	4.000	TITLE	SCREW SS M4X12 PAN COMBI(HEAD DIA 8MM)	SHEET SIZE	A4	SHEET OF	1 OF 1
-------	-------	-------	--	------------	----	----------	--------