

1

2

3

PART NO	REV
FS-CI0171-AA	AA

A

A

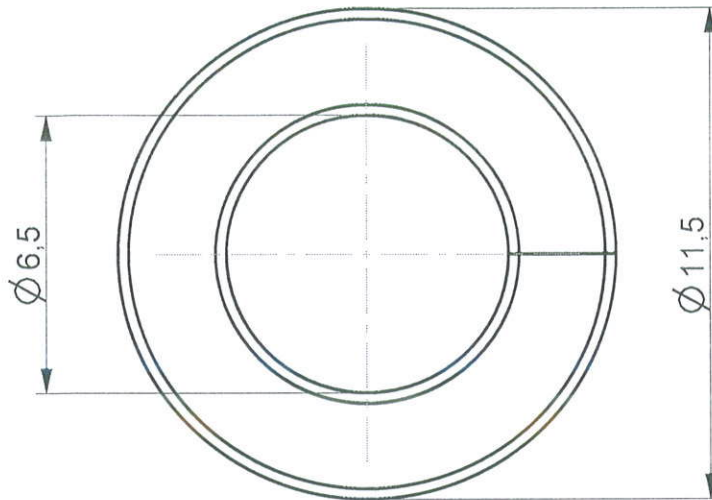

ELEVATION

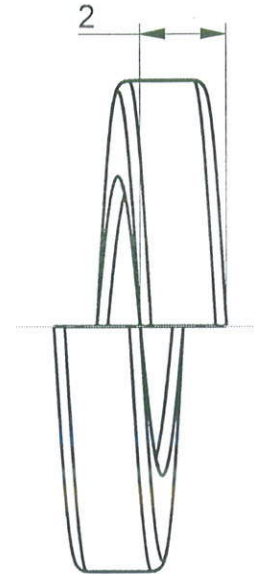

SIDE VIEW

B

B

C

C

MATING PARTS
M5 X 80 BOLT

## NOTES

1. ALL DIMENSIONS ARE IN MM.
2. PART SHOULD BE FREE FROM BURRS & SHARP EDGES.
3. DO NOT MEASURE FROM THE DRAWING.

AA	DRAWING RELEASE	--	KRS	--	
REV	DESCRIPTION OF CHANGE	LOC	BY	E.N.	DATE

ALL DIMENSIONS ARE IN MM

## GENERAL TOLERANCES

DIMENSIONS

0.5 6	6 30	30 120	120 400	400 1000
----------	---------	-----------	------------	-------------

ALL RIGHTS RESERVED  
**MAYA APPLIANCES (P) LTD,**  
 CHENNAI-97,  
 INDIA.

TOLERANCES ±

0.1	0.2	0.3	0.4	0.8
-----	-----	-----	-----	-----

MATERIAL

SPRING STEEL

GRADE

--

ANGULAR TOLERANCE- ±1/2°

CONCENTRICITY- Ø0.1

COLOUR

YELLOW

FINISH

PLATED

REFERENCE

--

\* CRITICAL DIMENSIONS.

PART NO : FS-CI0171-AA

REV AA

ASSEMBLY

COMMON

DENSITY  
(g/mm<sup>3</sup>)

--

DRAWN BY

DATE

6-11-19

MODEL

--

MASS  
(kg)

--

CHECKED BY

DATE

28-4-23

DO NOT MEASURE FROM DRAWING

THIRD ANGLE  
PROJECTION

APPD BY

DATE

2/5/23

SCALE  
6.000

TITLE

M6 SPRING WASHER (SS)

SHEET SIZE  
A4SHEET OF  
1 OF 1

1

2

3

D

D

E

E