

1

2

3

PART NO	REV
FS-CI0170-AA	AA

A

A

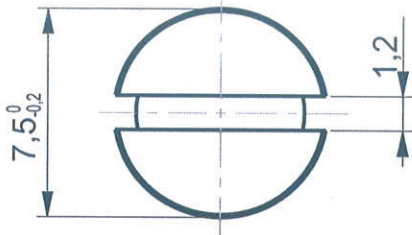

PLAN

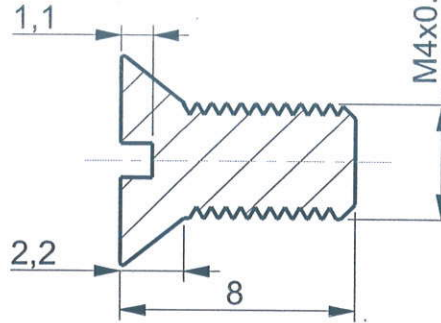

SECTION A-A

B

B

C

C

MATING PARTS

NOTES

1. ALL DIMENSIONS ARE IN MM.
2. PART SHOULD BE FREE FROM BURRS & SHARP EDGES.
3. DO NOT MEASURE FROM THE DRAWING.

AA	DRAWING RELEASE	-	KRS	--	
REV	DESCRIPTION OF CHANGE	LOC	BY	E.N.	DATE

ALL DIMENSIONS ARE IN MM

GENERAL TOLERANCES

DIMENSIONS

$\frac{0.5}{6}$	$\frac{6}{30}$	$\frac{30}{120}$	$\frac{120}{400}$	$\frac{400}{1000}$
-----------------	----------------	------------------	-------------------	--------------------

ALL RIGHTS RESERVED
MAYA APPLIANCES (P) LTD,
 CHENNAI-97,
 INDIA.

TOLERANCES \pm

0.1	0.2	0.3	0.4	0.8
-----	-----	-----	-----	-----

MATERIAL

SS

GRADE

304

ANGULAR TOLERANCE- $\pm 1/2^\circ$ CONCENTRICITY- $\varnothing 0.1$

COLOUR

NATURAL

FINISH

POLISHED

REFERENCE

--

* CRITICAL DIMENSIONS.

PART NO : FS-CI0170-AA

REV AA

ASSEMBLY

COMMON

DENSITY
(g/mm³)

--

DRAWN BY

DATE

6-11-19

MODEL

--

MASS
(kg)

--

CHECKED BY

A. S. D. J.

DATE

28-12-23

DO NOT MEASURE FROM DRAWING

THIRD ANGLE
PROJECTION

APPD BY

A. S. D. J.

DATE

18/1/24

SCALE
4.000

TITLE

SCREW CSK M4 X 8 RH(SS)

SHEET SIZE
A4SHEET OF
1 OF 1

1

2

3

D

D

E

E