

PART NO	REV
FS-CI0148-AA	A

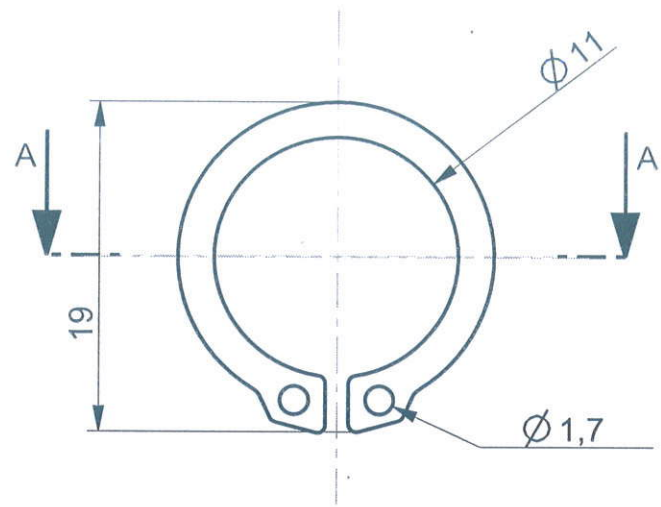

TOP VIEW

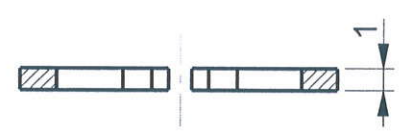

SECTION A-A

TECHNICAL SPEC:

- 1) FOR SHAFT SIZE=12mm
- 2) HARDNESS-60 HRC

NOTES

- 1. ALL DIMENSIONS ARE IN MM.
- 2. PART SHOULD BE FREE FROM BURRS & SHARP EDGES.
- 3. DO NOT MEASURE FROM THE DRAWING.

MATING PARTS
AL.CEN.SHAFT

AA	DRAWING RELEASE	-	KRS	-	
REV	DESCRIPTION OF CHANGE	LOC	BY	E.N.	DATE

ALL DIMENSIONS ARE IN MM	GENERAL TOLERANCES					ALL RIGHTS RESERVED <b>MAYA APPLIANCES (P) LTD,</b> CHENNAI-97, INDIA.			
DIMENSIONS	0.5/6	6/30	30/120	120/400	400/1000				

TOLERANCES ±	0.1	0.2	0.3	0.4	0.8	MATERIAL	SPRING STEEL	GRADE	--
ANGULAR TOLERANCE- ±1/2°	CONCENTRICITY- Ø0.1					COLOUR	BLACK	FINISH	HARDENED

REFERENCE	--	* CRITICAL DIMENSIONS.	PART NO : FS-CI0148-AA			REV	A
-----------	----	------------------------	------------------------	--	--	-----	---

ASSEMBLY	COMMON	DENSITY (g/mm <sup>3</sup> )	--	DRAWN BY		DATE	11-5-19
----------	--------	------------------------------	----	----------	--	------	---------

MODEL	--	MASS (kg)	--	CHECKED BY	<i>A.S.B</i>	DATE	28-12-23
-------	----	-----------	----	------------	--------------	------	----------

DO NOT MEASURE FROM DRAWING	THIRD ANGLE PROJECTION		APPD BY	<i>K. Subramanian</i>	DATE	18/1/24
-----------------------------	------------------------	--	---------	-----------------------	------	---------

SCALE	3.000	TITLE	CIRCLIP NO.12		SHEET SIZE	A4	SHEET OF	1 OF 1
-------	-------	-------	---------------	--	------------	----	----------	--------