

1

2

3

PART NO	REV
FS-CI0111-AA	A

A

A



LEFT SIDE VIEW

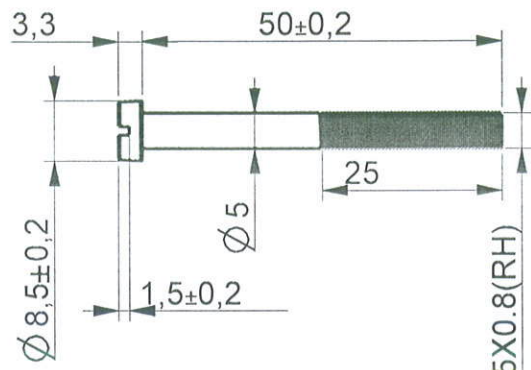

ELEVATION

M5X0.8(RH)

B

B

C

C

MATING PARTS
NUT M5
M5 INSERT
SPLIT MOTOR

NOTES

- ALL DIMENSIONS ARE IN MM.
- PART SHOULD BE FREE FROM BURRS & SHARP EDGES.
- DO NOT MEASURE FROM THE DRAWING.

REV	DESCRIPTION OF CHANGE	LOC	BY	E.N.	DATE
-----	-----------------------	-----	----	------	------

D

D

ALL DIMENSIONS ARE IN MM	GENERAL TOLERANCES					ALL RIGHTS RESERVED MAYA APPLIANCES (P) LTD, CHENNAI-97, INDIA.			
DIMENSIONS	$\frac{0.5}{6}$	$\frac{6}{30}$	$\frac{30}{120}$	$\frac{120}{400}$	$\frac{400}{1000}$	MATERIAL	MS	GRADE	-
TOLERANCES ±	0.1	0.2	0.3	0.4	0.8	COLOUR	YELLOW	FINISH	PLATING
ANGULAR TOLERANCE- ± 1/2°	CONCENTRICITY- Ø 0.1								

E

E

REFERENCE	--	* CRITICAL DIMENSIONS.	PART NO : FS-CI0111-AA		REV	A
ASSEMBLY	COMMON	DENSITY (g/mm ³)	DRAWN BY	DATE	27-7-17	
MODEL	--	MASS (kg)	CHECKED BY	DATE	26-4-23	
DO NOT MEASURE FROM DRAWING	THIRD ANGLE PROJECTION		APPD BY	DATE	28/4/23	
SCALE	TITLE	SCREW M5X50 MS(HALF THREAD)			SHEET SIZE	SHEET OF
1	2	3			A4	1 OF 1

1

2

3