

PART NO	REV
FS-C10104-AB-A	

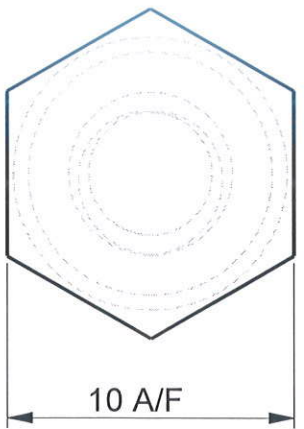

PLAN

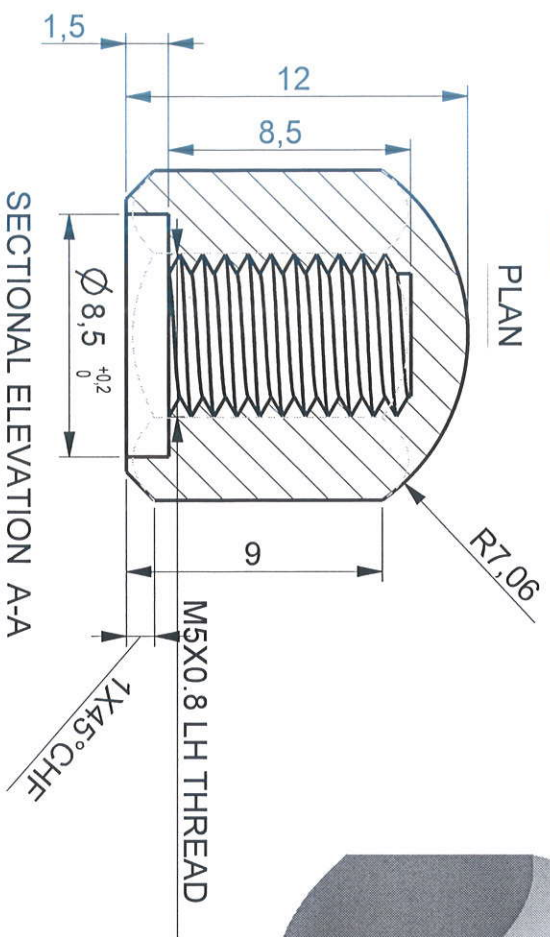
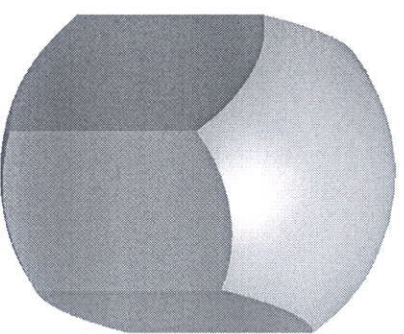

SECTIONAL ELEVATION A-A

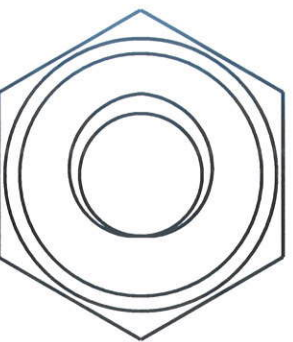

BOTTOM VIEW

MATING PARTS

NOTES
 1. ALL DIMENSIONS ARE IN MM.
 2. PART SHOULD BE FREE FROM BURRS & SHARP EDGES.
 3. DO NOT MEASURE FROM THE DRAWING.

ALL RIGHTS RESERVED
MAYA APPLIANCES (P) LTD,
 CHENNAI-97,
 INDIA.

REV	DESCRIPTION OF CHANGE	LOC	BY	E.N.	DATE
GENERAL TOLERANCES					
DIMENSIONS	0.5/6	6/30	30/120	120/400	400/1000
TOLERANCES ±	0.1	0.2	0.3	0.4	0.8
ANGULAR TOLERANCE - ±1/2°	CONCENTRICITY - Ø0.1				
REFERENCE		PART NO : FS-C10104-AB-A		REV	A
ASSEMBLY	JAR	DRAWN BY		DATE	8-12-17
MODEL		CHECKED BY		DATE	
DO NOT MEASURE FROM DRAWING		THIRD ANGLE PROJECTION	APPD BY	DATE	
SCALE	TITLE	DOME NUT M5X0.8LH THREAD SMALL		SHEET SIZE	A4
				SHEET OF	1 OF 1

ALL DIMENSIONS ARE IN MM.

SCALE	TITLE	DOME NUT M5X0.8LH THREAD SMALL		SHEET SIZE	A4	SHEET OF	1 OF 1
-------	-------	--------------------------------	--	------------	----	----------	--------