

1

2

3

PART NO	REV
FS-CI0091-AA	

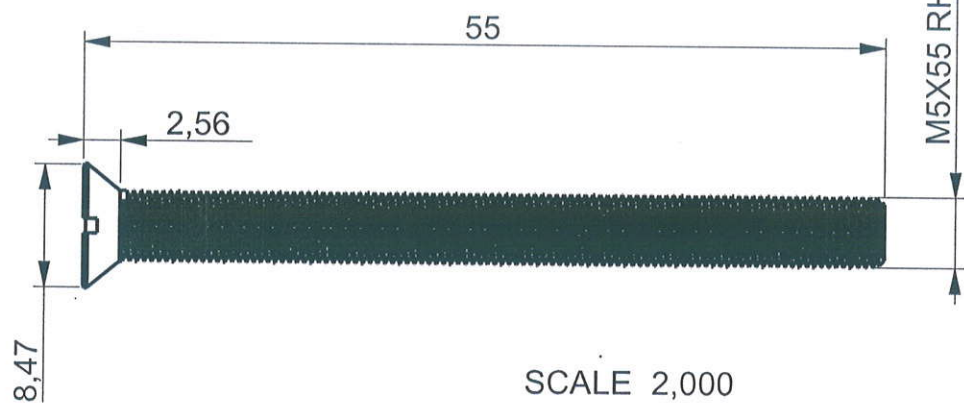
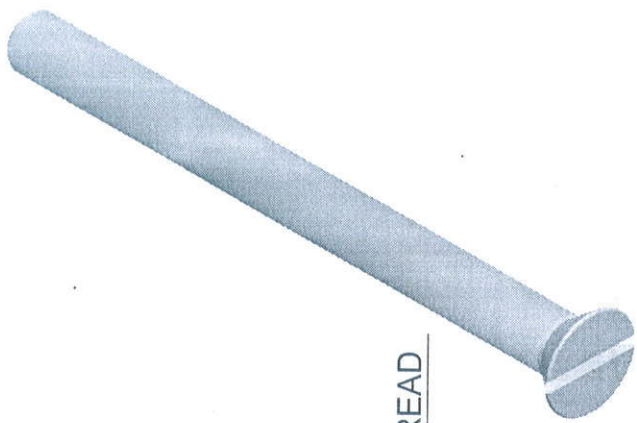

MATING PARTS
HOB GLASS

SCALE 2,000

- NOTES
- 1.ALL DIMENSIONS ARE IN MM.
 - 2.PART SHOULD BE FREE FROM BURRS & SHARP EDGES.
 - 3.DO NOT MEASURE FROM THE DRAWING.

REV	DESCRIPTION OF CHANGE	LOC	BY	E.N.	DATE
-----	-----------------------	-----	----	------	------

ALL DIMENSIONS ARE IN MM	GENERAL TOLERANCES					ALL RIGHTS RESERVED MAYA APPLIANCES (P) LTD, CHENNAI-97, INDIA.			
DIMENSIONS	$\frac{0.5}{6}$	$\frac{6}{30}$	$\frac{30}{120}$	$\frac{120}{400}$	$\frac{400}{1000}$	MATERIAL	MS	GRADE	----
TOLERANCES \pm	0.1	0.2	0.3	0.4	0.8	COLOUR	YELLOW	FINISH	ZINC PLATED

REFERENCE	* CRITICAL DIMENSIONS.		PART NO : FS-CI0091-AA			REV	A
ASSEMBLY	GAS STOVE	DENSITY (g/mm ³)	DRAWN BY		DATE	18-4-16	
MODEL		MASS (kg)	CHECKED BY		DATE	28-12-23	
DO NOT MEASURE FROM DRAWING	THIRD ANGLE PROJECTION		APPD BY		DATE	19/1/24	
SCALE	TITLE	SCREW CSK M5X55MM MS				SHEET SIZE	SHEET OF
						A4	1 OF 1

1

2

3