

1

2

3

PART NO	REV
FS-CI0079-AA	A

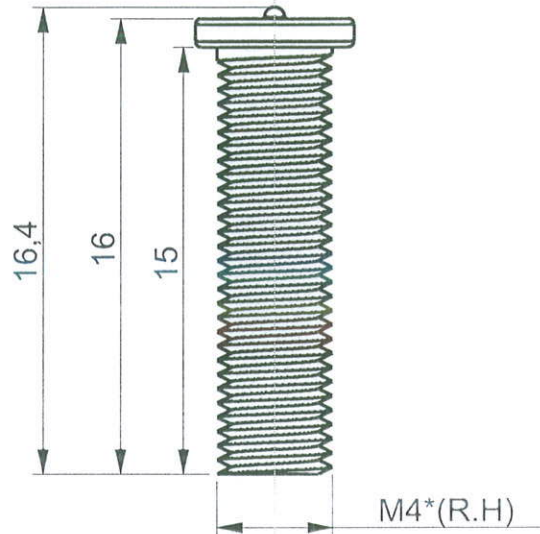
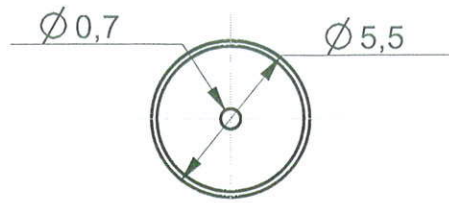

MATING PARTS
DRIP TRAY

NOTES

1. ALL DIMENSIONS ARE IN MM.
2. PART SHOULD BE FREE FROM BURRS & SHARP EDGES.
3. DO NOT MEASURE FROM THE DRAWING.

A	DRAWING RELEASE	--	KRS	--	
REV	DESCRIPTION OF CHANGE	LOC	BY	E.N.	DATE

ALL DIMENSIONS ARE IN MM

GENERAL TOLERANCES

ALL RIGHTS RESERVED
MAYA APPLIANCES (P) LTD,
 CHENNAI-97,
 INDIA.

DIMENSIONS	$\frac{0.5}{6}$	$\frac{6}{30}$	$\frac{30}{120}$	$\frac{120}{400}$	$\frac{400}{1000}$
------------	-----------------	----------------	------------------	-------------------	--------------------

TOLERANCES \pm	0.1	0.2	0.3	0.4	0.8
------------------	-----	-----	-----	-----	-----

MATERIAL	SS	GRADE	SS 304
----------	----	-------	--------

ANGULAR TOLERANCE- $\pm 1/2^\circ$	CONCENTRICITY- $\varnothing 0.1$	COLOUR	NATURAL	FINISH	POLISHED
------------------------------------	----------------------------------	--------	---------	--------	----------

REFERENCE	--	* CRITICAL DIMENSIONS.	PART NO : FS-CI0079-AA	REV	A
-----------	----	------------------------	------------------------	-----	---

ASSEMBLY	GAS STOVE	DENSITY (g/mm ³)	--	DRAWN BY		DATE	
----------	-----------	------------------------------	----	----------	--	------	--

MODEL	--	MASS (kg)	--	CHECKED BY	<i>Ajsh</i>	DATE	28-4-23
-------	----	-----------	----	------------	-------------	------	---------

DO NOT MEASURE FROM DRAWING	THIRD ANGLE PROJECTION		APPD BY	<i>Anchoy</i>	DATE	2/5/23
-----------------------------	------------------------	--	---------	---------------	------	--------

SCALE	TITLE	SHEET SIZE	SHEET OF
4.000	STUD WELD SCREW M4X15	A4	1 OF 1

1

2

3