

PART NO	REV
FS-C10058-AA	A

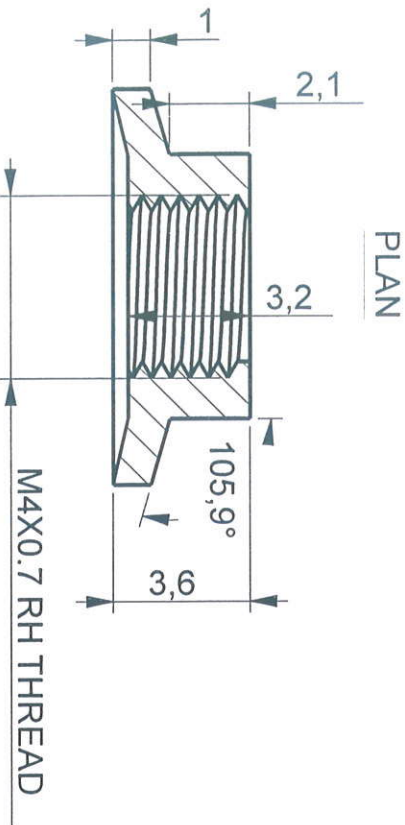
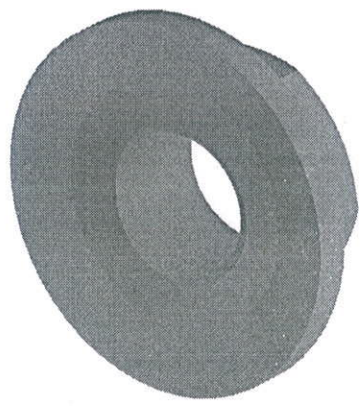
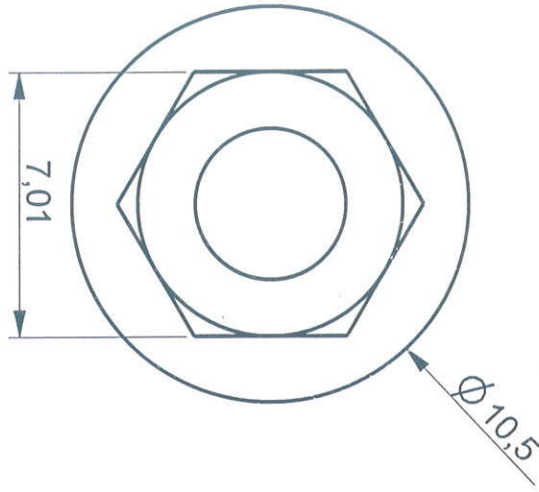

MATING PARTS

SECTION A-A

NOTES

- 1. ALL DIMENSIONS ARE IN MM.
- 2. PART SHOULD BE FREE FROM BURRS & SHARP EDGES.
- 3. DO NOT MEASURE FROM THE DRAWING.

REV	DESCRIPTION OF CHANGE	LOC	BY	E.N.	DATE
ALL DIMENSIONS ARE IN MM		GENERAL TOLERANCES			
DIMENSIONS	0.5 6	6 30	30 120	120 400	400 1000
TOLERANCES ±	0.1	0.2	0.3	0.4	0.8
ANGULAR TOLERANCE- ±1/2°	CONCENTRICITY- Ø0.1				
REFERENCE		* CRITICAL DIMENSIONS.		PART NO : FS-C10058-AA	
ASSEMBLY	MG	DENSITY (g/mm <sup>3</sup> )	DRAWN BY	DATE	REV A
MODEL		MASS (kg)	CHECKED BY	DATE	
DO NOT MEASURE FROM DRAWING		THIRD ANGLE PROJECTION	APPD BY	DATE	
SCALE	TITLE	M4 FLANGE NUT		SHEET SIZE	SHEET OF
				A4	1 OF 1

ALL RIGHTS RESERVED  
**MAYA APPLIANCES (P) LTD,**  
 CHENNAI-97,  
 INDIA.

Drawn by: *A.S. Raj*

Checked by: *A.S. Raj*

Appd by: *[Signature]*

Date: *19/11/24*