

| | |
|--------------|-----|
| PART NO | REV |
| FS-CI0051-AA | A |

0.5 X 30° TYP

M4X0.7(R.H)

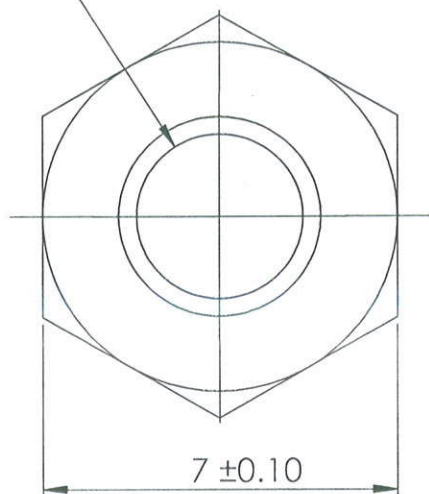
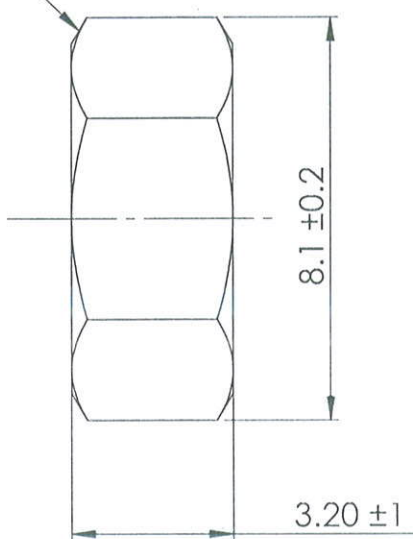

SIDE VIEW

FRONT VIEW

| | | | | | |
|-----|-----------------------|-----|----|------|------------|
| A | DRAWING RELEASE | -- | -- | -- | 20-07-2016 |
| REV | DESCRIPTION OF CHANGE | LOC | BY | E.N. | DATE |

ALL DIMENSIONS ARE IN "mm"

GENERAL TOLERANCES

ALL RIGHTS RESERVED
MAYA APPLIANCES(P) LTD,
 CHENNAI-97
 INDIA.

| | | | | | |
|------------|-------|------|--------|---------|----------|
| DIMENSIONS | 0.5/6 | 6/30 | 30/120 | 120/400 | 400/1000 |
|------------|-------|------|--------|---------|----------|

| | | | | | |
|--------------|-----|-----|-----|-----|-----|
| TOLERANCES ± | 0.1 | 0.2 | 0.3 | 0.4 | 0.8 |
|--------------|-----|-----|-----|-----|-----|

| | | | |
|----------|----|-------|----|
| MATERIAL | MS | GRADE | -- |
|----------|----|-------|----|

| | |
|--------------------------|----------------------|
| ANGULAR TOLERANCES ±1/2° | CONCENTRICITY- φ 0.1 |
|--------------------------|----------------------|

| | | | |
|--------|---------|--------|----|
| COLOUR | NATURAL | FINISH | -- |
|--------|---------|--------|----|

| | | | | | |
|-----------|----|-----------------------|-----------------------|-----|---|
| REFERENCE | -- | * CRITICAL DIMENSIONS | PART NO: FS-CI0051-AA | REV | A |
|-----------|----|-----------------------|-----------------------|-----|---|

| | | | | | | |
|----------|--------|-----------------|----------|----------|------|------------|
| ASSEMBLY | COMMON | DENSITY (g/mm³) | DRAWN BY | GANESH.E | DATE | 20-07-2016 |
|----------|--------|-----------------|----------|----------|------|------------|

| | | | | | | |
|-------|----|-----------|------------|--------------------|------|---------|
| MODEL | -- | MASS (Kg) | CHECKED BY | <i>[Signature]</i> | DATE | 28-4-23 |
|-------|----|-----------|------------|--------------------|------|---------|

| | | | | | |
|--|--------------------------|---------|--------------------|------|--------|
| DO NOT MEASURE FROM DRAWING REMOVE BURRS & SHARP EDGES | THIRD ANGLE PROJECTION - | APPD BY | <i>[Signature]</i> | DATE | 2/5/23 |
|--|--------------------------|---------|--------------------|------|--------|

| | | | | | | |
|-----------|-------|-----------|--|------------|----|--------------|
| SCALE:7:1 | TITLE | NUT M4-MS | | SHEET SIZE | A4 | SHEET 1 OF 1 |
|-----------|-------|-----------|--|------------|----|--------------|