

1

2

3

PART NO	REV
FS-CI0033-AA	AA

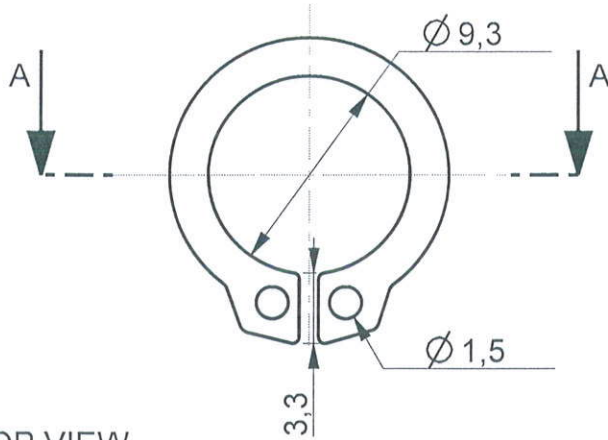

TOP VIEW

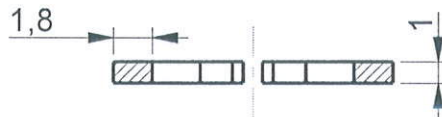

SECTION A-A

MATING PARTS
MOTOR SHAFT

TECHNICAL SPEC:

- 1)FOR SHAFT SIZE=10mm
- 2)HARDNESS-60 HRC

AA	DRAWING RELEASE				--	KRS	--	
REV	DESCRIPTION OF CHANGE				LOC	BY	E.N.	DATE
ALL DIMENSIONS ARE IN MM		GENERAL TOLERANCES				ALL RIGHTS RESERVED		
DIMENSIONS		$\frac{0.5}{6}$	$\frac{6}{30}$	$\frac{30}{120}$	$\frac{120}{400}$	MAYA APPLIANCES (P) LTD, CHENNAI-97, INDIA.		
TOLERANCES \pm		0.1	0.2	0.3	0.4	0.8	MATERIAL	SPRING STEEL
ANGULAR TOLERANCE- $\pm 1/2^\circ$		CONCENTRICITY- $\phi 0.1$			COLOUR	BLACK	GRADE	HARDENED
REFERENCE	--	* CRITICAL DIMENSIONS.			PART NO : - FS-CI0033-AA		REV	AA
ASSEMBLY	COMMON	DENSITY (g/mm ³)	--	DRAWN BY		DATE		
MODEL	--	MASS (kg)	--	CHECKED BY	<i>Jo-my</i>	DATE	27-1-23	
DO NOT MEASURE FROM DRAWING REMOVE BURRS & SHARP EDGES		THIRD ANGLE PROJECTION		APPD BY	<i>Debay</i>	DATE	6/2/23	
SCALE	TITLE	CIRCLIP NO.10				SHEET SIZE	SHEET OF 1 OF 1	
3.000						A4		

1

2

3