

1

2

3

PART NO	REV
FS-CI0032-AA	AA

A

A



SECTION A-A

M5X0.8(R.H)

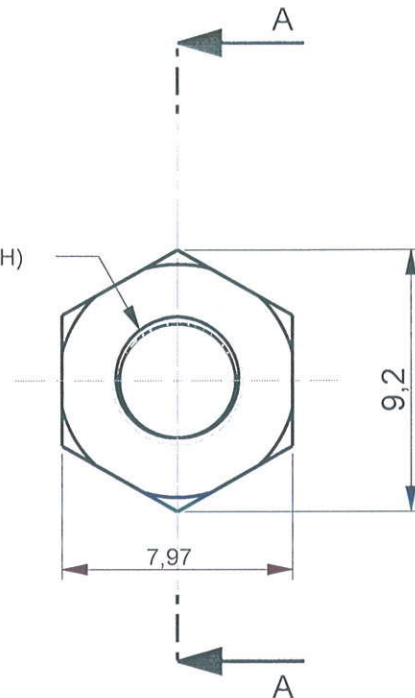

ELEVATION

MATING PARTS
TOP CASING
BOTTOM CASING
M5X80 BOLT
M5X40 BOLT

NOTES

1. ALL DIMENSIONS ARE IN MM.
2. PART SHOULD BE FREE FROM BURRS & SHARP EDGES.
3. DO NOT MEASURE FROM THE DRAWING.

AA	DRAWING RELEASE	--	KRS	--	
REV	DESCRIPTION OF CHANGE	LOC	BY	E.N.	DATE

ALL DIMENSIONS ARE IN MM

GENERAL TOLERANCES

ALL RIGHTS RESERVED
MAYA APPLIANCES (P) LTD,
 CHENNAI-97,
 INDIA.

DIMENSIONS

$\frac{0.5}{6}$	$\frac{6}{30}$	$\frac{30}{120}$	$\frac{120}{400}$	$\frac{400}{1000}$
-----------------	----------------	------------------	-------------------	--------------------

TOLERANCES \pm

0.1	0.2	0.3	0.4	0.8
-----	-----	-----	-----	-----

MATERIAL

SS

GRADE

304

ANGULAR TOLERANCE- $\pm 1/2^\circ$ CONCENTRICITY- $\varnothing 0.1$

COLOUR

NATURAL

FINISH

POLISHED

REFERENCE

--

* CRITICAL DIMENSIONS.

PART NO : FS-CI0032-AA

REV AA

ASSEMBLY

COMMON

DENSITY
(g/mm³)

--

DRAWN BY

DATE

14-5-15

MODEL

--

MASS
(kg)

--

CHECKED BY

A. S. M

DATE

27-1-23

DO NOT MEASURE FROM DRAWING

THIRD ANGLE
PROJECTION

APPD BY

A. S. M

DATE

*6/2/23*SCALE
4.000

TITLE

NUT M5-SS

SHEET SIZE
A4SHEET OF
1 OF 1

1

2

3

D

D

E

E