

1

2

3

PART NO	REV
FS-CI0030-AA	B

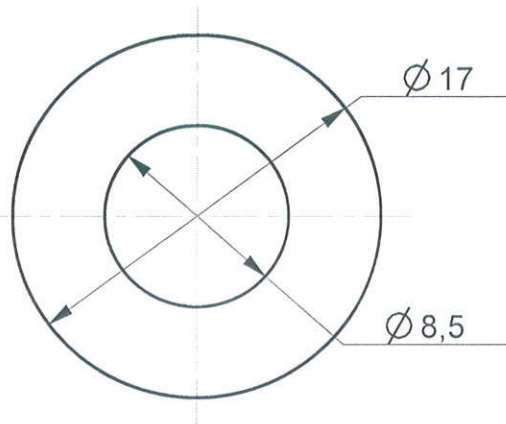

TOP VIEW

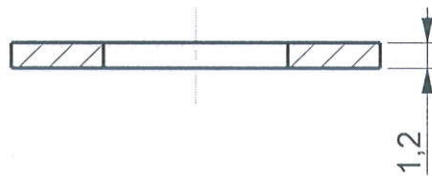

SECTION A-A

MATING PARTS
STONE HOLDER

B	DIA 8.3 TO 8.5 MM CHANGED	--	ANAND	--	26-06-15
A	DRAWING RELEASE	--	KRS	--	12-12-14
REV	DESCRIPTION OF CHANGE	LOC	BY	E.N.	DATE

ALL DIMENSIONS ARE IN MM	GENERAL TOLERANCES					ALL RIGHTS RESERVED MAYA APPLIANCES (P) LTD, CHENNAI-97, INDIA.			
DIMENSIONS	$\frac{0.5}{6}$	$\frac{6}{30}$	$\frac{30}{120}$	$\frac{120}{400}$	$\frac{400}{1000}$	MATERIAL	SS	GRADE	304
TOLERANCES \pm	0.1	0.2	0.3	0.4	0.8	COLOUR	NATURAL	FINISH	POLISHED
ANGULAR TOLERANCE- $\pm 1/2^\circ$	CONCENTRICITY- $\varnothing 0.1$					COLOUR	NATURAL	FINISH	POLISHED

REFERENCE	--	* CRITICAL DIMENSIONS.	PART NO : FS-CI0030-AA		REV	B
ASSEMBLY	COMMON	DENSITY (g/mm ³)	--	DRAWN BY	DATE	26-6-15
MODEL	--	MASS (kg)	--	CHECKED BY	DATE	27-1-23
DO NOT MEASURE FROM DRAWING REMOVE BURRS & SHARP EDGES	THIRD ANGLE PROJECTION			APPD BY	DATE	6/2/23
SCALE	TITLE	WASHER 8.2X17X1.2-SS			SHEET SIZE	SHEET OF
3.000					A4	1 OF 1

1

2

3