

1 2 3

PART NO	REV
FS-CI0012-AA	AA

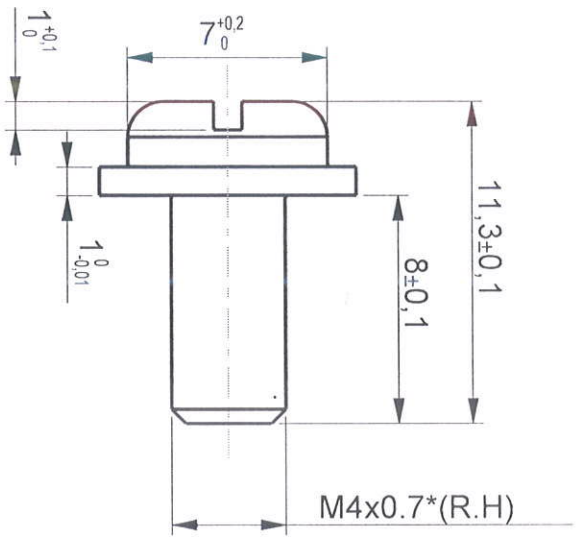
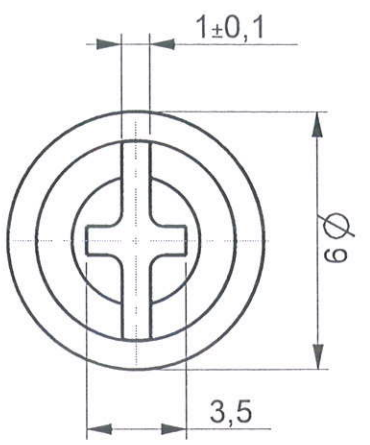

ELEVATION  
SIDE VIEW

- MATING PARTS
- TOP COVER
- BOTTOM COVER
- GEAR BOX
- TOP CASING

NOTES  
 1. ALL DIMENSIONS ARE IN MM.  
 2. PART SHOULD BE FREE FROM BURRS & SHARP EDGES.  
 3. DO NOT MEASURE FROM THE DRAWING.

AA	DRAWING RELEASE		-	KRS	--	
REV	DESCRIPTION OF CHANGE		LOC	BY	E.N.	DATE

ALL DIMENSIONS ARE IN MM		GENERAL TOLERANCES				ALL RIGHTS RESERVED <b>MAYA APPLIANCES (P) LTD,</b> CHENNAI-97, INDIA.			
DIMENSIONS	0.5 6	6 30	30 120	120 400	400 1000				
TOLERANCES ±	0.1	0.2	0.3	0.4	0.8	MATERIAL	MS	GRADE	--
ANGULAR TOLERANCE- ±1/2°	CONCENTRICITY- Ø0.1		COLOUR	YELLOW	FINISH	NICKEL PLATED			

REFERENCE	--	* CRITICAL DIMENSIONS.		PART NO : FS-CI0012-AA		REV	AA
ASSEMBLY	COMMON	DENSITY (g/lmm <sup>3</sup> )	--	DRAWN BY		DATE	
MODEL	--	MASS (kg)	--	CHECKED BY	<i>[Signature]</i>	DATE	20-12-23
DO NOT MEASURE FROM DRAWING		THIRD ANGLE PROJECTION		APPD BY	<i>[Signature]</i>	DATE	23/1/23

SCALE	4.000	TITLE	SCREW M4X8 MS-EARTH		SHEET SIZE	A4	SHEET OF	1 OF 1
-------	-------	-------	---------------------	--	------------	----	----------	--------

1 2 3