

PART NO	REV
CM-MG1154-AA	A

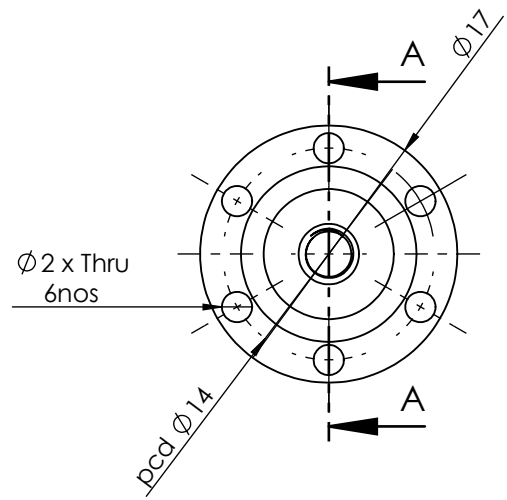

TOP VIEW

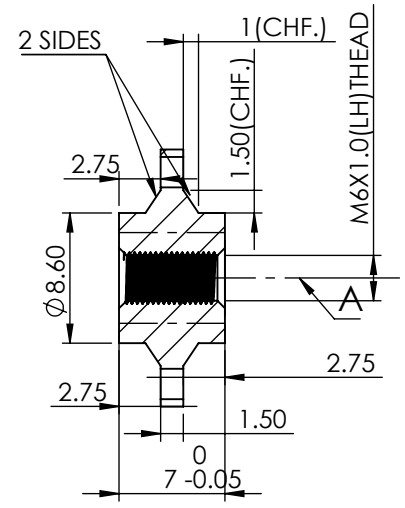

SECTION A-A

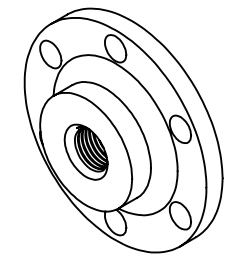

ISOMETRIC VIEW

NOTES:-
 All dimensions are in "mm"
 Part should be free from burrs and sharp edges
 Don't measure from the drawing

ALL DIMENSIONS ARE IN "mm"	GENERAL TOLERANCES					ALL RIGHTS RESERVED MAYA APPLIANCES(P) LTD, CHENNAI-97 INDIA.				
DIMENSIONS	0.5/6	6/30	30/120	120/400	400/1000	MATERIAL	BRASS	GRADE	--	
TOLERANCES ±	0.1	0.2	0.3	0.4	0.8	COLOUR	--	FINISH	MACHINED	
ANGULAR TOLERANCES ±1/2°	CONCENTRICITY-φ 0.1					PART NO:	CM-MG1154-AA		REV	A
REFERENCE	--	* CRITICAL DIMENSIONS			DRAWN BY	ANAND	DATE	13-3-24		
ASSEMBLY	MG	DENSITY (g/mm ³)	--	CHECKED BY		DATE				
MODEL	--	MASS (kg)	--	APPD BY		DATE				
DO NOT MEASURE FROM DRAWING REMOVE BURRS & SHARP EDGES	THIRD ANGLE PROJECTION				DATE					
SCALE:2:1	TITLE	INSERT BRASS JAR COUPLER (OD 17 X T 1.5 MM) MG				SHEET SIZE	A4	SHEET 1 OF 1		